

WORTH COUNTY BOARD OF COMMISSIONERS
October 25, 2023

REQUEST FOR PROPOSALS

RE: Generator & Automatic Transfer Switch Purchase & Installation

The Worth County Board of Commissioners is accepting sealed proposals for the purchase and installation of a generator and automatic transfer switch for the Georgia State Patrol Building that is **currently under construction**.

Sealed proposals will be accepted at the Worth County Board of Commissioners Office until Tuesday, November 14th at 2:00 p.m. at which time the proposals will be publicly opened and read aloud. Proposals must be in a sealed envelope plainly marked in the lower left-hand corner "Sealed Proposal – Generator & Automatic Transfer Switch Purchase & Installation" and addressed to the County Clerk, Angela Harrah at 201 N. Main St., Suite 30, Sylvester Ga. 31791. Proposals will not be accepted after the called time.

The RFP is on file for review during normal business hours and may be obtained by sending a request to the Worth County Board of Commissioners, 201 N. Main St., Suite 30, Sylvester, GA. 31791. The RFP may also be obtained from the Worth County Board of Commissioners website at www.worthcountyboc.com.

Any questions regarding the RFP may be directed to Nicole Jones, Administrative Liaison, at 229-776-8246.

The County reserves the right to reject any or all proposals when it is determined that the rejection of one or more of the proposals is in the best interest of the County. It is the policy of the County to promote equal opportunity, regardless of race, color, religion, sex, familiar status, handicap, or national origin.

Thank you for your interest in doing business with Worth County.

RFP Generator & Automatic Transfer Switch Purchase & Installation Specifications

The Worth County Board of Commissioners is looking to have a new generator unit and transfer switch unit supplied and installed at the Georgia State Patrol Building, 107 Airport Rd., Sylvester, Ga. 31791.

1. Equipment (Recommendations)

a. Industrial gaseous 9.0L V-8 engine-driven generator, consisting of the following features and accessories, or anything equivalent to the below recommendations:

- Stationary Emergency-Standby rated
- 150 kW Rating, wired for 120/208 VAC three phase, 60 Hz
- Permanent Magnet Excitation
- LP Vapor fuel system
- Standard Weather Protective Enclosure, Steel
- UL2200
- EPA Non-Emergency
- H-100 Control Panel
 - Meets NFPA 99 and 110 requirements
 - Temp Range -40 to 70 degrees C
 - Digital Microprocessor:
 - Two 4-line x 20 displays, full system status
 - 3 Phase sensing, +/- 0.25% digital voltage regulation
 - RS232, RS485 and Canbus remote ports
 - Waterproof connections
 - All engine sensors are 4-20ma for minimal interference
 - 2-wire start controls for any 2-wire transfer switch
- 21 Light Annunciator – Surface
- Remote Emergency Stop Switch, break-glass, shipped loose
- 110 AH, 925 CCA Group 31 Battery, with rack, installed
- Standard MLCB, 80% rated thermal-magnetic
 - 600 amp
- Battery Charger, 10 Amp, NFPA 110 compliant, installed
- Coolant Heater, 1500W, 120VAC
- Std set of 1 Manual
- 120V GFCI and 240V Outlet
- Alternator Tropical Coating
- Engine Run Relay
- Extreme Cold Weather Kit – Heated Crankcase Breather System
- Flex Fuel Line
- Flush Mount Annunciator Kit

- 5-Year Comprehensive Warranty

b. Transfer switch:

- 600 Amp, 3 pole, 120/208 VAC three phase, 60 Hz, with 2-Wire Start Circuit **or anything equivalent to the below recommendations:**
 - Utility Voltage Sensing Controls:
 - Adjustable Drop-out and Pick-up
 - Adjustable Utility Interrupt Delay
 - Adjustable Logic Controls:
 - Minimum Standby Voltage
 - Minimum Standby Frequency
 - Engine Warmup
 - Return to Utility
 - Engine Cooldown
 - Transfer on Exercise
- 1 Owner's Manual
- Double Set of Form C Aux Cont
- Any Breaker (3 Cycle)
- Withstand and Close-on Rating – 200kA Fuse Rating
- Withstand and Close-on Rating – 50kA Any breaker
- Enclosure Heater
- IO Board – 4 Inputs, 4 Outputs
- CSA – C22.2 No. 178
- UL Listed 1008 by ETL
- Controller Cover, Padlockable, Black
- NEMA 3R Enclosure
- Non-Service Entrance Rated
- Any Breaker (3 Cycle)
- In Phase Only Transfer
- Five Year Extended Warranty

**RFP Generator & Automatic Transfer Switch Purchase & Installation
Requirements:**

The drawing below shows what is required from the generator and power-switch.
Any questions about the specifications or requirements can be addressed to Nicole Jones,
Administrative Liaison at (229) 776-8246, or by email at: njones@worthcountyboc.com.



- GENERAL NOTES:**
- 1. PROVIDE 2 SETS #500 ALUMINUM MCA, #3/0G ALUMINUM #2/AN.C.
 - 2. PROVIDE #200000 ALUMINUM #2G ALUMINUM #3/AN.C.
 - 3. SERIES RATING ACCEPTABLE. PROVIDE ENGRAVED LABEL ON FRONT OF PANELS. USE WHITE LETTER ON RED BACKGROUND SERIES RATED CIRCUIT BREAKERS.
 - 4. PROVIDE LABEL GENERATOR DOCUMENT. PROVIDE 600A/3P/3R S.E. RATED DISCONNECT SWITCH FOR ALL WIRING.
 - 5. PROVIDE LABEL GENERATOR DOCUMENT. PROVIDE 600A/3P/3R S.E. RATED DISCONNECT SWITCH FOR ALL WIRING.
 - 6. SEE SERVICE GRADING DETAIL 5-E-5.
 - 7. SEE GENERATOR PAD DETAIL 5-E-5.
 - 8. # N.C. TO GEN STATUS PANEL. ARCHITECT/OWNER TO LOCATE.

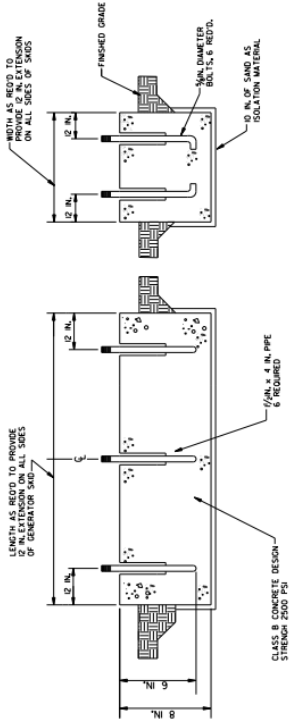

5 GENERATOR PAD DETAIL
E-5 NOT TO SCALE

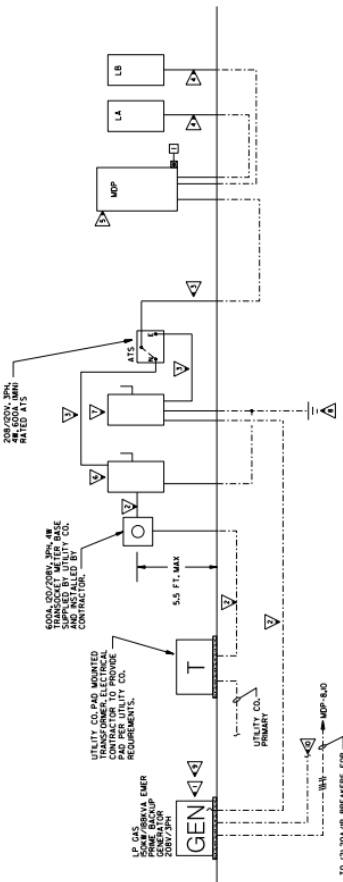

1 POWER RISER DIAGRAM
E-5 NOT TO SCALE

T.V.S.S.
MSP SERVICE PANELS. PROVIDE 5+2 CONDUCTORS IN 1/2" C FROM 100A/3P BREAKER IN SUPPLYING PANEL. PROVIDE BREAKER.

Cost Proposal Form

Generator & Automatic Transfer Switch Purchase & Installation

1. The undersigned Contractor has carefully examined the bidding documents relating to the construction of the Generator & Automatic Transfer Switch Purchase & Installation project, located at:

WORTH COUNTY BOARD OF COMMISSIONERS
201 N. MAIN STREET, SUITE 30
SYLVESTER, GA. 31791

2. The following is the bid proposal of the undersigned Contractor for the performance of all work on the above-described project, in accordance with the provisions of the RFP documents and any/or all addenda received:

Base Price Proposal: \$ _____

Projected Start Date for Project: _____

Completion Date for Project: _____

Company: _____

Signed by: _____

Printed Name: _____

Title: _____

Date: _____

Mailing
Address:

Email Address:

Phone
Number:

I certify that this formal bid is made without prior understanding, agreement, or connection with any corporation, firm, or person submitting a bid for the same service, materials, supplies, or equipment, and is in all respects fair and without collusion or fraud. I agree to abide by all conditions of this bid and certify that I am authorized to sign this formal bid for the bidder. I understand that all information included in this bid is public knowledge.

Authorized Signature: _____